

Lecture 1

Introduction to Microcontrollers

Components of a microprocessor/controller

- CPU: Central Processing Unit
- I/O: Input /Output
- Bus: Address bus & Data bus
- Memory: RAM & ROM
- Timer
- Interrupt
- Serial Port
- Parallel Port

General-purpose microprocessor:

- CPU for Computers
- Commonly no RAM, ROM, I/O on CPU chip itself

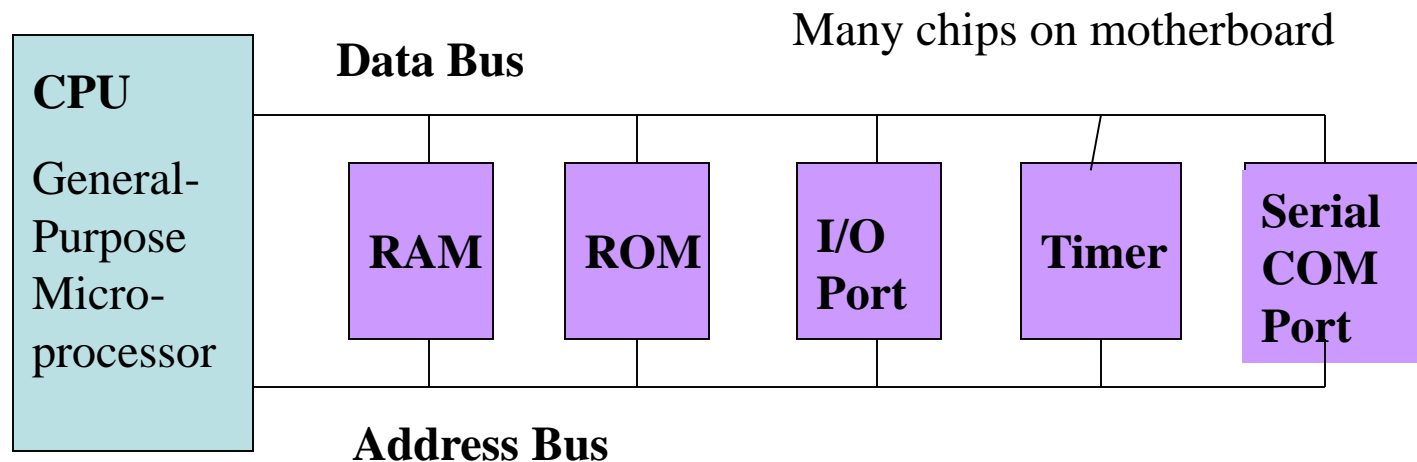

Microcontroller :

- A single-chip computer
- On-chip RAM, ROM, I/O ports...
- Example : Motorola's 6811, Intel's 8051, Zilog's Z8 and PIC 16X

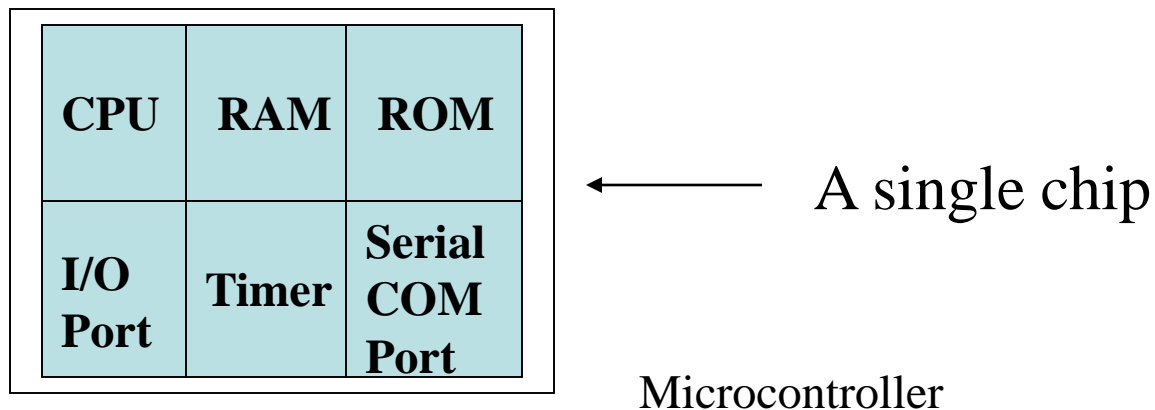

Microprocessor vs. Microcontroller

Microprocessor

- CPU is stand-alone, RAM, ROM, I/O, timer are separate
- designer can decide on the amount of ROM, RAM and I/O ports.
- expensive
- versatility
- general-purpose
- High processing power
- High power consumption
- Instruction sets focus on processing-intensive operations
- Typically 32/64 – bit
- Typically deep pipeline (5-20 stages)

Microcontroller

- CPU, RAM, ROM, I/O and timer are all on a single chip
- fixed amount of on-chip ROM, RAM, I/O ports
- for applications in which cost, power and space are critical
- single-purpose (control-oriented)
- Low processing power
- Low power consumption
- Bit-level operations
- Instruction sets focus on control and bit-level operations
- Typically 8/16 bit
- Typically single-cycle/two-stage pipeline

Some Popular Microcontrollers...

- 8051
- Microchip Technology PIC
- Atmel AVR
- Texas Instruments MSP430 (16-bit)

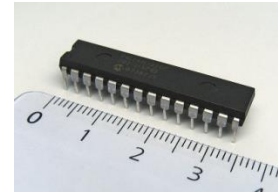

Review questions

- What are the main differences between a microprocessor and a microcontroller in terms of
 - Architecture
 - Applications
 - Instruction set

Example

- A uP running at 600 MHz has an average CPI of 1.2 and a average power consumption of 400 mW, while a uC running at 12 MHz with a two cycle datapath has a power consumption of 24 mW.
 - Calculate their respective MIPS
 - Which one is more efficient in MIPS/mW?

Example 2

- The previous uP costs 100\$, while the respective uC costs 0.96 \$
 - Which is more efficient in MIPS/\$?